



TECHNICAL DATA

TYPE CZ VACUUM ON-LOAD TAP CHANGER FOR DRY TYPE TRANSFORMER

HM0.154.1102



SHANGHAI HUAMING POWER EQUIPMENT CO., LTD.

General

1. General	2
2. Technical specifications	3
3. Model designation	4
4. Terms and definitions	5
5. Special design	6
6. Motor drive unit	7
7. Operation controllers	7
8. Accessories	8
9. Appendixes	8
Appendix 1 CZI OLTC overall dimension,9 operation positions	9
Appendix 2 CZI OLTC overall dimension,7 operation positions	10
Appendix 3 CZI OLTC overall dimension,13 operation positions	11
Appendix 4 CZ OLTC mounted on supporting frame, MDU on the right side, 9 positions	12
Appendix 5 CZ OLTC mounted on supporting frame, MDU on the left side,9 positions	13
Appendix 6 CZ OLTC mounted in enclosure, MDU on the right side, 7 positions	14
Appendix 7 CZ OLTC mounted in enclosure, MDU on the left side, 7 positions	15
Appendix 8 CZ OLTC mounted in enclosure, MDU on the right side, 9 positions	16
Appendix 9 CZ OLTC mounted in enclosure, MDU on the left side, 9 positions	17
Appendix 10 Disposal drawing of 3 units of single phase CZ OLTC	18
Appendix 11 Installation dimension of SHM-III motor drive unit	19
Appendix 12 Installation dimension of CMA7 motor drive unit	20
Appendix 13 Installation dimension of bevel gearbox	21
Appendix 14 Schematic drawing of horizontal insulation drive shaft	22

1. General

Type CZ vacuum on-load tap changer (hereafter refer as CZ or CZ OLTC) is applicable to indoor dry type transformer, through which the tap changes can be realized for voltage regulation when transformer is energized. CZ OLTC is designed in single phase structure, If it is applied for three-phase transformer, three units of CZ must be linked mechanically, and operated by one motor drive unit. CZ can be used for both STAR and DELTA winding connection.

CZ OLTC adopts quick resistance transition switching principle. During tap switching process, the tap selector selects the tap firstly and then the diverter switch performs switching under the load. The vacuum interrupters work as arcing contact, and the mechanical contacts carry the main circuit current. Hence, CZ OLTC has good capability for arc extinguishing and reliable operation for long time.

The basic connections of CZ OLTC shown in below Fig 1

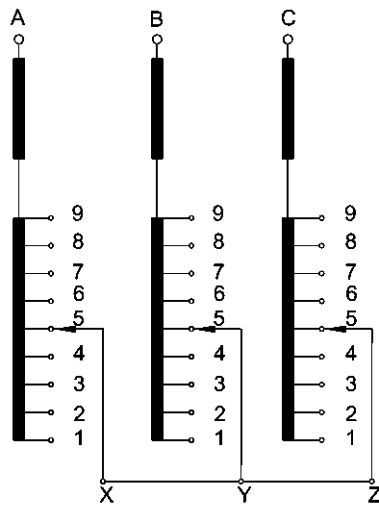

Regulating at neutral point of star connection.

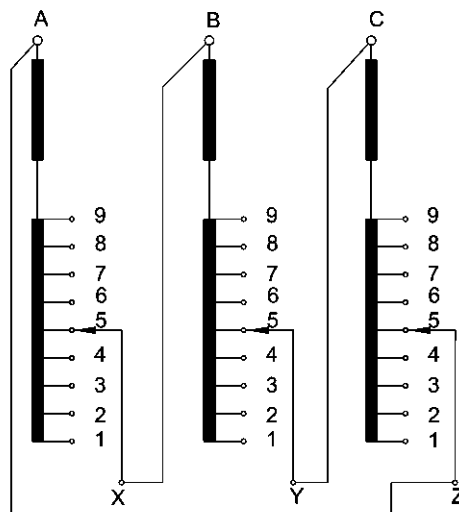

Regulating for delta connection

Fig 1 Basic Connection Modes of Regulating Winding

2. Technical specifications

CZ OLTC is designed and manufactured according to IEC60214-1:2003. Please refer to Table 1 for the technical specifications.

Table 1 Type CZ Vacuum OLTC Technical Parameters

No.	On Load Tap Changer		CZ500	3 × CZ500
1	Number of Phase And Application		1 Single Phase	3 Any 3-phase Connection
2	Max. Rated Through-Current (A)		500	
3	Short-circuit current test (kA)	Thermal (3s)	5	
		Dynamic (Peak)	12.5	
4	Max. Rated Step Voltage (V)		900	
5	Rated Step Capacity (kVA)		250	
6	Max. Operating Positions		13, in linear regulation	
7	Rated Frequency (Hz)		50 or 60	
8	Insulation To Ground	Highest Voltage For Equipment Um (kV)	40.5	
		Rated separate source AC withstand voltage(kV/50Hz,1min)	85	
		Rated lightning impulse withstand voltage (kV,1.2/50μs)	200	
9	Internal Insulation	Between Tap In Service And Pre-Selected Tap	Rated separate source AC withstand voltage(kV/50Hz,1min)	5
			Rated lightning impulse withstand voltage (kV,1.2/50μs)	20
	Across Fine Tap Winding	Rated separate source AC withstand voltage(kV/50Hz,1min)	20	
		Rated lightning impulse withstand voltage (kV,1.2/50μs)	80	
10	Ambient Temperature of Operation (°C)		-25~+65	
11	Ambient Media of Operation		Air	
12	Adopted Motor Drive Unit		SHM-III or CMA7	
13	Electric Life		Not Less Than 300,000 Operations	
14	Mechanical Life		Not Less Than 800,000 Operations	
15	OLTC Weight (Excluding Motor Drive Unit, Approx.)		80	240

3. Model designation

3.1 Description of model

CZ OLTC has various models due to difference of the phase, max. rated through current, highest voltage for equipment and operation positions. Variations will be described in the CZ model. See below Fig.2 for details:

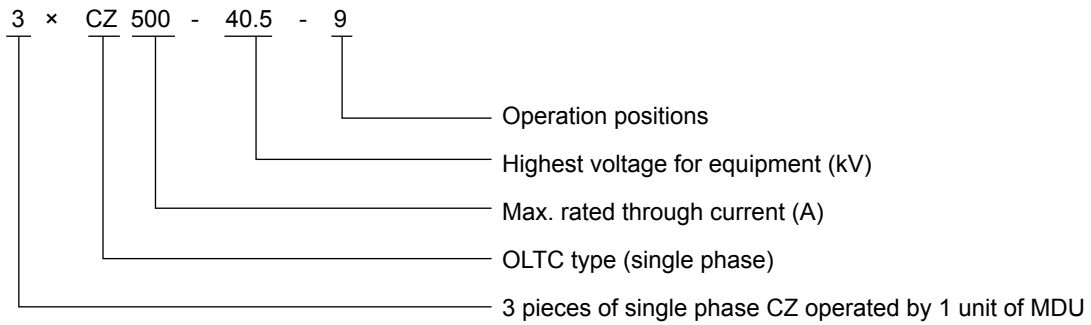

Fig. 2 Designation of CZ OLTC

3.2 Basic connection diagram of tap selector

Below Fig.3 is the typical connection diagram of CZ OLTC with 9 operation positions, we will provide the connection diagram according to the number of operation position as requirement.

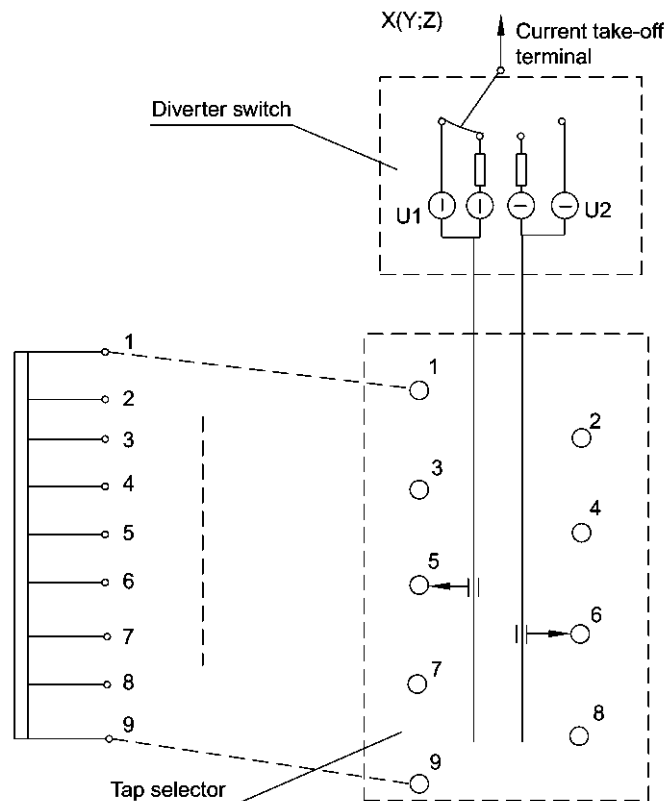

Fig 3 Basic Connection Diagram of Tap Selector

4. Terms and definitions

4.1 Through current

Rated through current I_u :

The current flowing through an OLTC towards the external circuit, which the apparatus is capable of transferring from one tap to the other at the relevant rated step voltage and which can be carried continuously while meeting the requirement.

Max. rated through current I_{um} :

The highest rated through-current for which the tap changer is designed for and which forms the basis for all current related tests.

4.2 Step voltage

Rated step voltage (U_i)

For each value of rated through-current, the highest permissible voltage between terminals which are intended to be connected to successive taps of the transformer.

Maximum rated step voltage (U_{im})

The highest value of the rated step voltage for which the tap-changer is designed.

4.3 Rated step capacity P_{stN}

The rated step capacity is determined by OLTC circuit structure and breaking capacity of vacuum interrupter.

According to Fig.4 Curve of CZ OLTC Rated Step Capacity., the max. rated through current versus the associated step voltage of the OLTC can be determined.

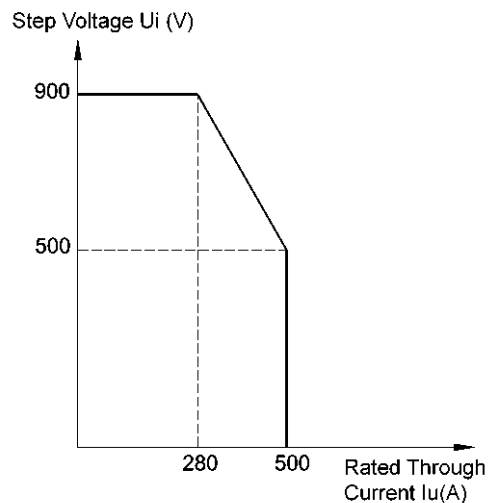

Fig 4 Curve of CZ OLTC Rated Step Capacity

4.4 Breaking capacity

According to IEC60214-1 (2003), Forty operations shall be performed at a current corresponding to twice the maximum rated through-current and at its relevant rated step voltage.

The OLTC breaking capacity $P_{st,max} = 2 P_{stN} \approx 2 I_{um} \times U_{stN}$

Where, P_{stN} is rated step capacity

I_{um} is max. rated through current

U_{stN} is relevant step voltage

4.5 Short-circuit current test

According to IEC 60214-1: 2003, all contacts continuously carrying the current shall be able to withstand 2s ($\pm 10\%$) short circuit test current without melting, deformation or mechanical damage. Meanwhile the starting peak current value shall be 2.5 ($\pm 5\%$) times of the root means square value of rated short circuit test current. Refer the short circuit test current values to Table 1. Type CZ Vacuum OLTC Technical Parameters.

4.6 Ambient air temperature

CZ OLTC is for indoor application, the CZ OLTC can be applied where ambient air temperature ranges from -25°C to $+65^{\circ}\text{C}$. Measures should be taken to avoid condensation and freeze on the OLTC.

4.7 Insulation level

Insulation level of type CZ is including insulation to ground and internal insulation. Insulation to ground is considered as 40.5kV insulation grade, and internal insulation level of CZ OLTC is according to the insulation grades satisfied to each part of a common dry transformer, see details in below Table 2

Table 2 CZ OLTC Insulation Level

(unit: kV)

Insulation level	Rated separate source AC withstand voltage (kV/50Hz, 1min)	Rated lightning impulse withstand voltage (kV, 1.2/50 μs)
To ground and between phases	85	200
Between adjacent taps	5	20
Across fine tap winding	20	80

Note: If transformer is placed in a cabinet grounded, sufficient insulation space should be considered between OLTC live parts and the transformer cabinet.

4.8 Installation of CZ OLTC

CZ OLTC shall be fixed on a supporting frame by its upper insulation plate. The supporting frame could be a part of transformer frame prepared by transformer manufacturer.

We can also provide the supporting frame or cabinet according to the requirements.

5. Special design

The special design of CZ OLTC mainly refers to tap positions location scheme on OLTC and number of operation positions. Up to date, we can provide the maximum operation positions up to 13 for linear regulation mode.

CZ OLTC can be provided together with supporting frame or cabinet according to customer's requirement. see details in Appendix.

6. Motor drive unit

CZ OLTC may be operated by SHM-III or CMA7 motor drive unit according to the requirement, please refer to table 3 for technical data.

SHM-III motor drive unit is proprietary and patented design of Huaming. SHM-III encloses the mechanical actuation part in the motor drive box and encapsulates the control part in the controller HMK8. It literally separates the mechanic and electric part.

Table 3 Motor Drive Unit Technical Specifications

Motor drive unit		SHM-III		CMA7	
Motor	Rated power (W)	750	1100	750	1100
	Rated voltage (V)	380,3AC/N		380/3AC	
	Rated current (A)	2.1	2.8	2.0	2.8
	Rate frequency(Hz)	50 or 60		50 or 60	
	Rotate speed (r.p.m.)	1400		1400	
Rated torque on drive shaft (Nm)		45	66	18	26
Revolution of the drive shaft per switching operation		33		33	
Revolution of the hand crank per switching operation		33		33	
Running time per switching operation (S)		5.6		About 5	
Max. operation positions		35		107	
Voltage for control circuit and heater circuit (V)		220/AC		220/AC	
Heater power (W)		50		50	
A.C. voltage test to ground (kV/50Hz, 1min)		2		2	
Approx. weight (kg)		73		90	
Protective degree		IP66		IP56	
Mechanical endurance (operations)		Not less than 2,000,000		Not less than 800,000	

Note: Please specify if special voltage required for motor, and control & heater circuit.

7. Operation controllers

7.1 HMK8 controller

HMK8 controller is the device for remote control of SHM-III motor drive unit; it realizes OLTC switching operation through SHM-III. HMK8 can display the OLTC switching operation status and tap positions.

HMK8 has BCD code position signal output (contact capacity:AC250V/5A or DC30V/5A) and remote control signal input (non potential contact), it can also communicate with host computer via RS485 interface to realize remote supervising of OLTC position.

HMK8 main technical data is as below, refer to HMK8 manual for more details.

Working voltage: 380V, 3AC/N

Power frequency: 50Hz/60Hz

Maximum operation positions: 35

Environment temperature: -10°C to 40°C Indoor

7.2 HMC-3C position indicator

HMC-3C OLTC position indicator is a support fitting for CMA7 and CMA9 motor drive unit, it can be used to indicate the OLTC position, and has the function of "1→N", "STOP", "N→1" control as well as remote control indicator lamp, its input is decimal code and output is BCD code. HMC-3C technical data is as below, refer to manual for more details.

Working voltage: 220V AC

Power frequency: 50Hz Maximum operation positions: 107

Environment temperature: -10°C to 40°C Indoor

7.3 Automatic voltage regulator ET-SZ6 and HMK-2A

Automatic voltage regulator ET-SZ6 and HMK-2A is adopted for OLTC automatic voltage regulation, ET-SZ6 can be used for parallel operation in model of master and slave, please refer to relevant manual for details.

8. Accessories

8.1 Horizontal shaft and vertical shaft

The horizontal shaft and vertical shaft is used for connection of the tap changer and motor drive unit via bevel gearbox.

The horizontal shaft is made from high strength insulation material, Its length will be determined by the insulation level required between phases when the tap changer is mounted on the transformer.

The vertical shaft is made of stainless steel.

8.2 Bevel gear box

The bevel gearbox connects the horizontal shaft of tap changer body and the vertical shaft of motor drive unit, it transmit the drive torque from motor drive unit to the tap changer. See installation dimension of bevel gearbox in Appendix 13.

9. Appendixes

Appendix 1. CZI OLTC overall dimension 9 operation positions

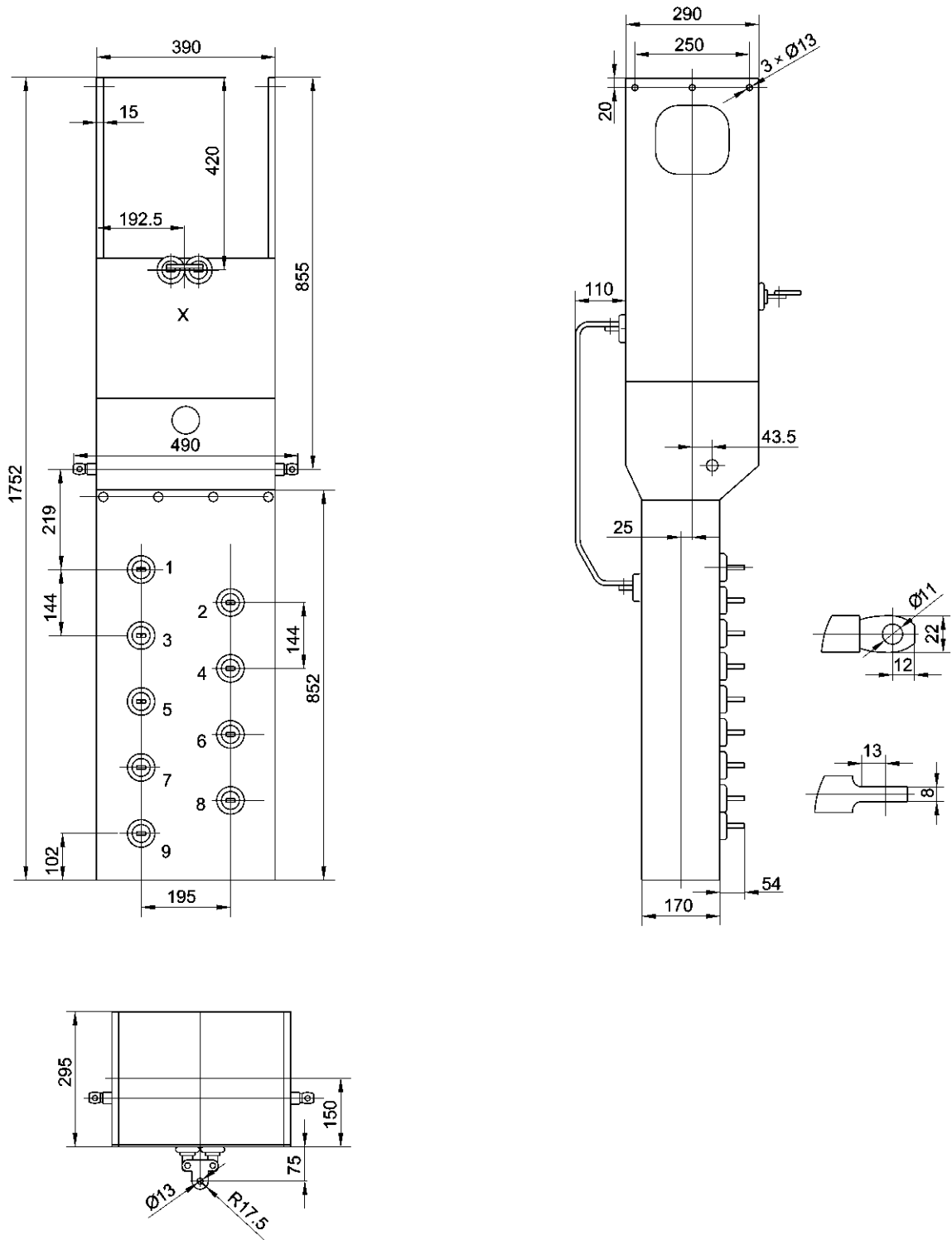

TYPE CZ VACUUM ON-LOAD TAP CHANGER TECHNICAL DATA

Appendix 2. CZI OLTC overall dimension 7 operation positions

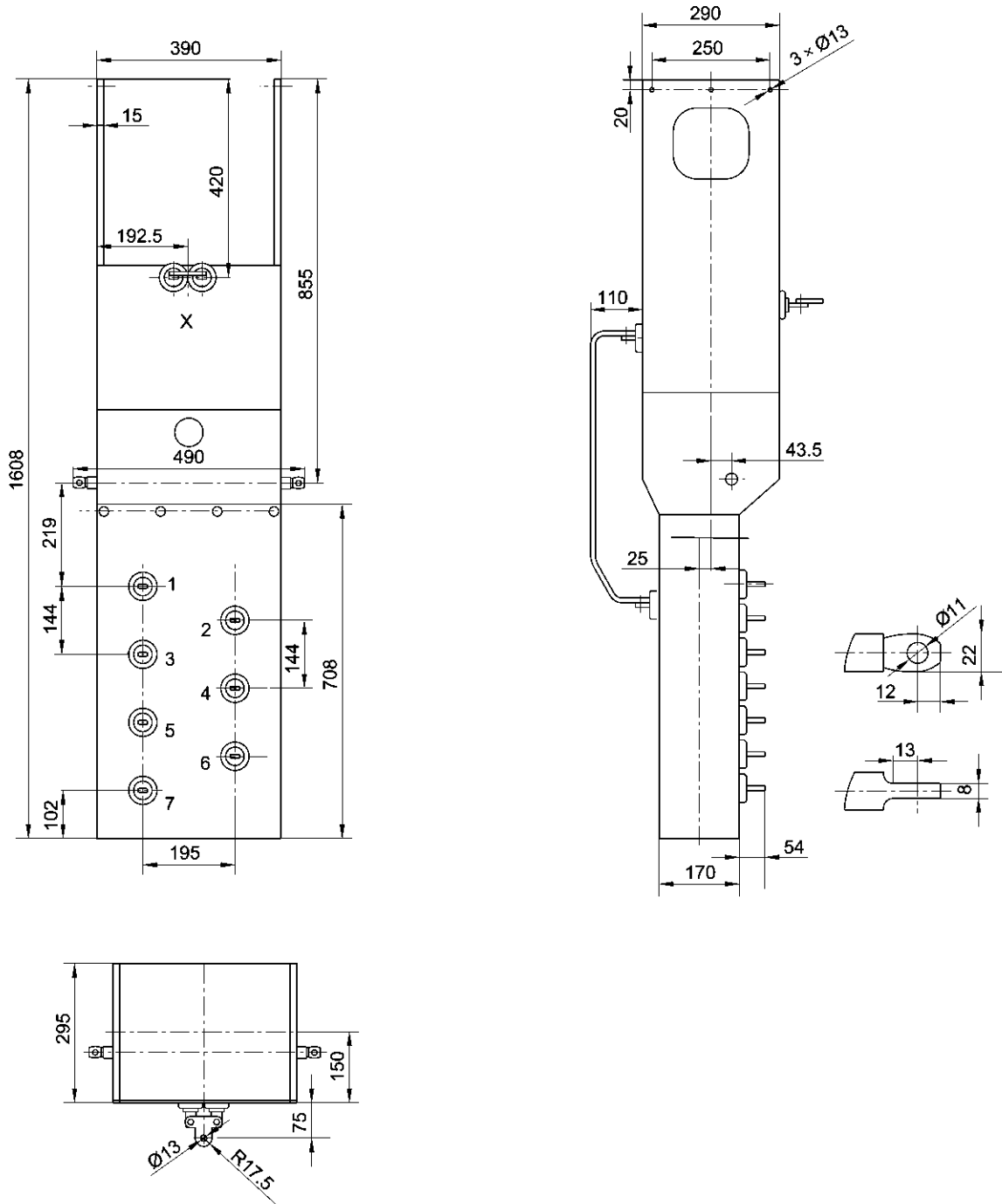

Appendix 3. CZI OLTC overall dimension 13 operation positions

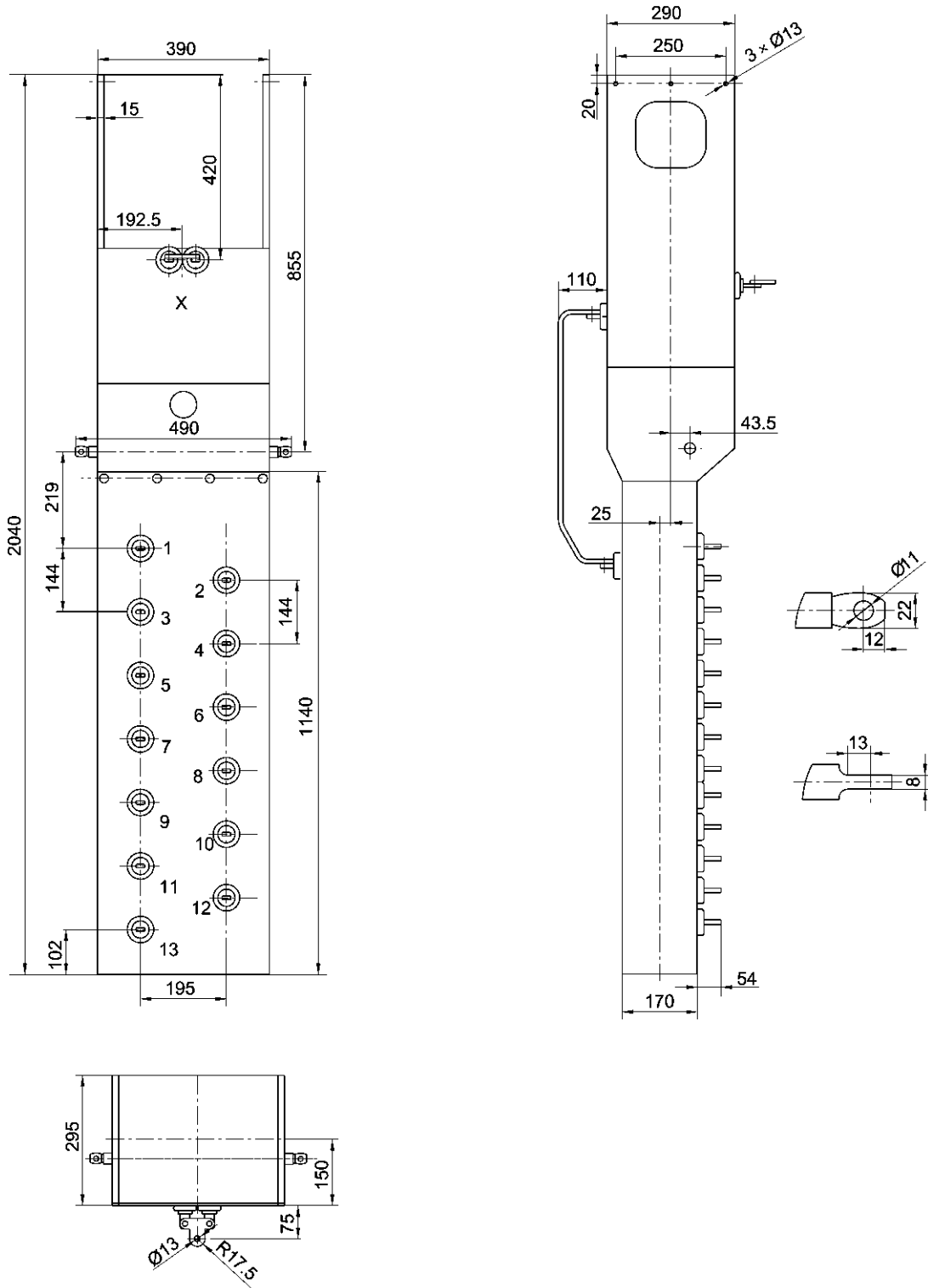

TYPE CZ VACUUM ON-LOAD TAP CHANGER TECHNICAL DATA

**Appendix 4. CZ OLTC mounted on supporting frame
MDU on the right side, 9 positions**

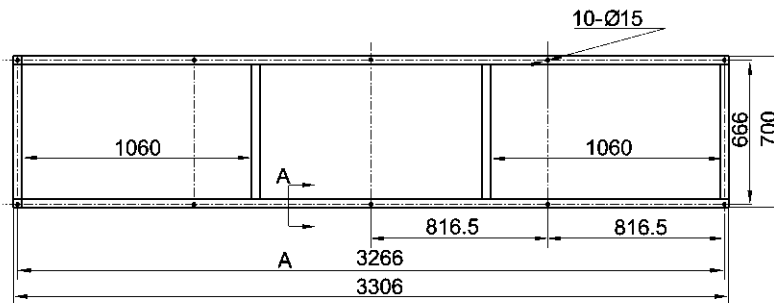
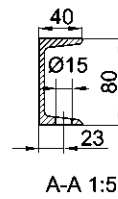
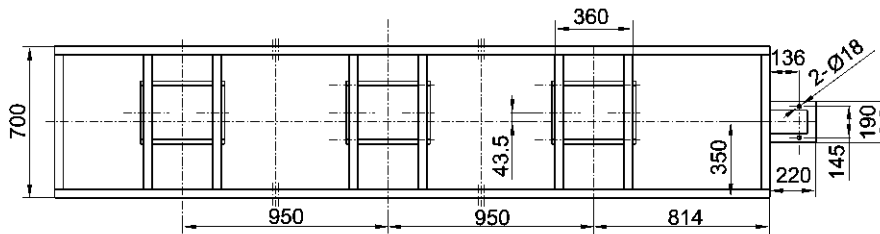
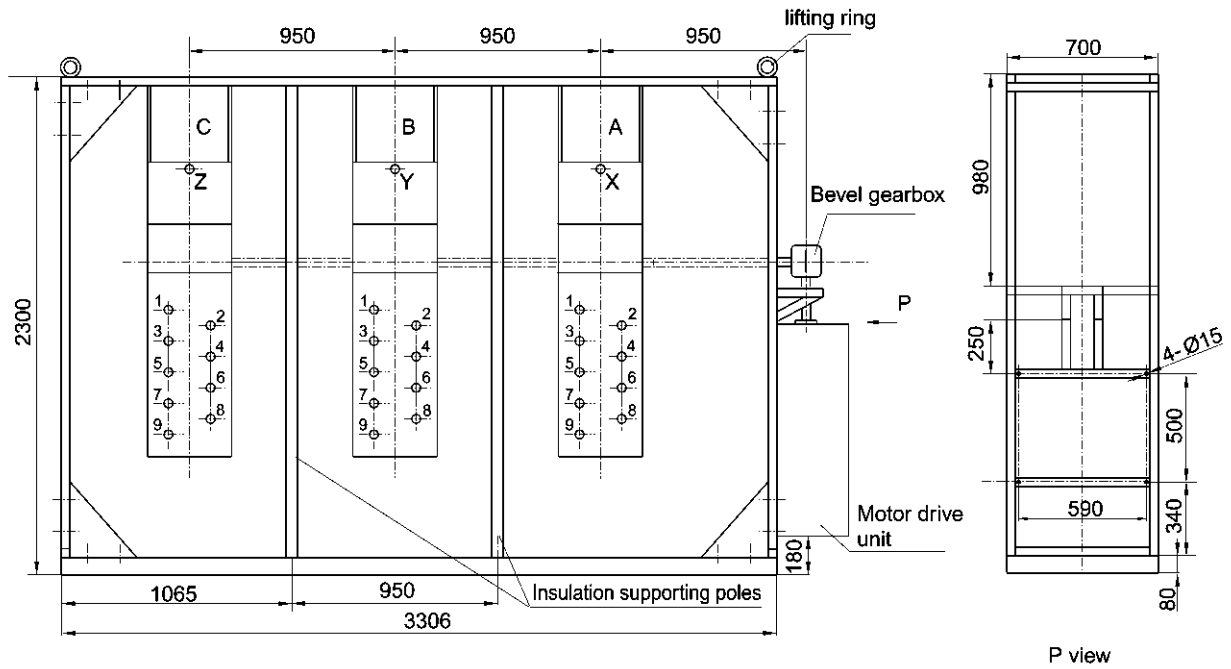

Installation holes on ground

Appendix 5. CZ OLTC mounted on supporting frame MDU on the left side, 9 positions

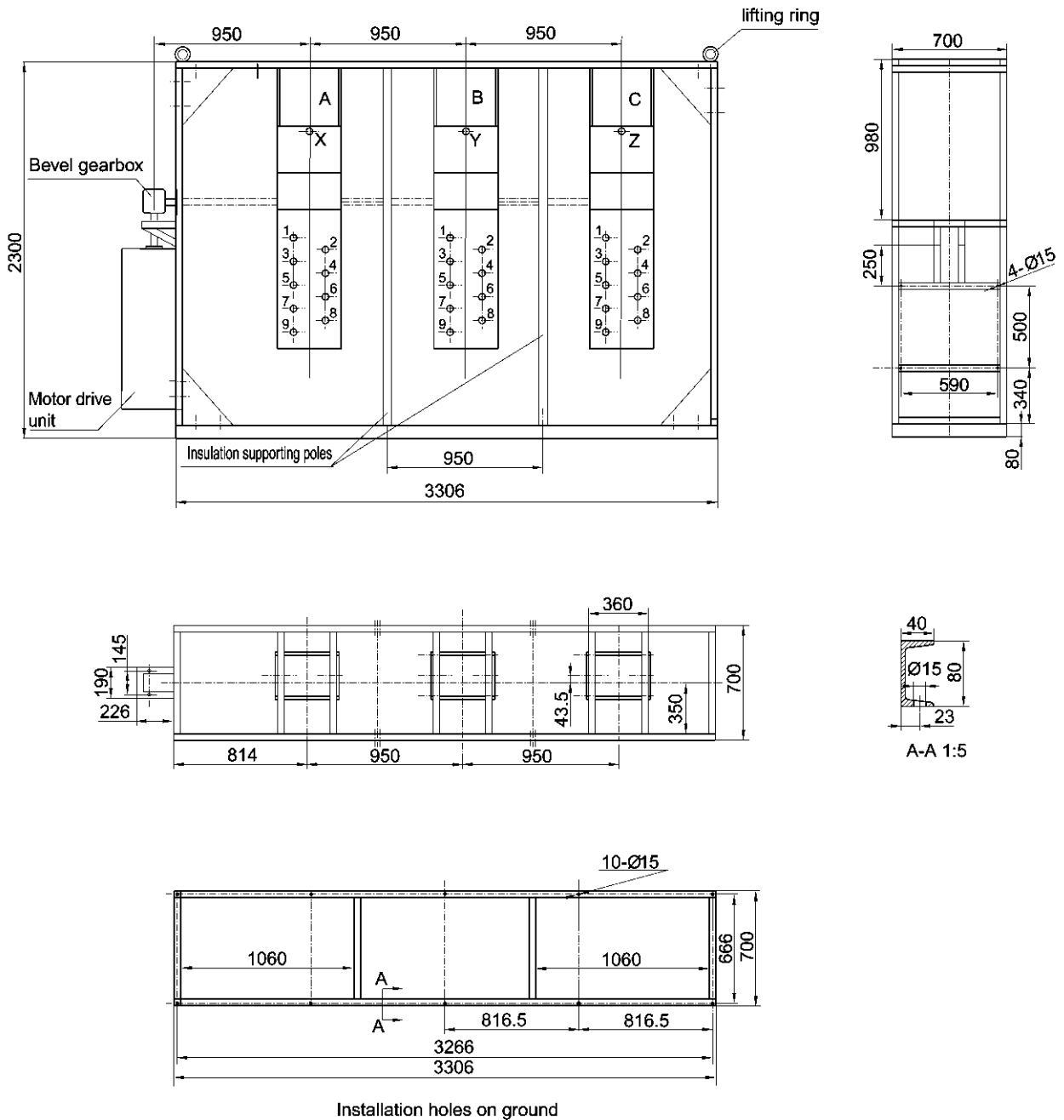

Appendix 6. CZ OLTC mounted in enclosure MDU on the right side, 7 positions

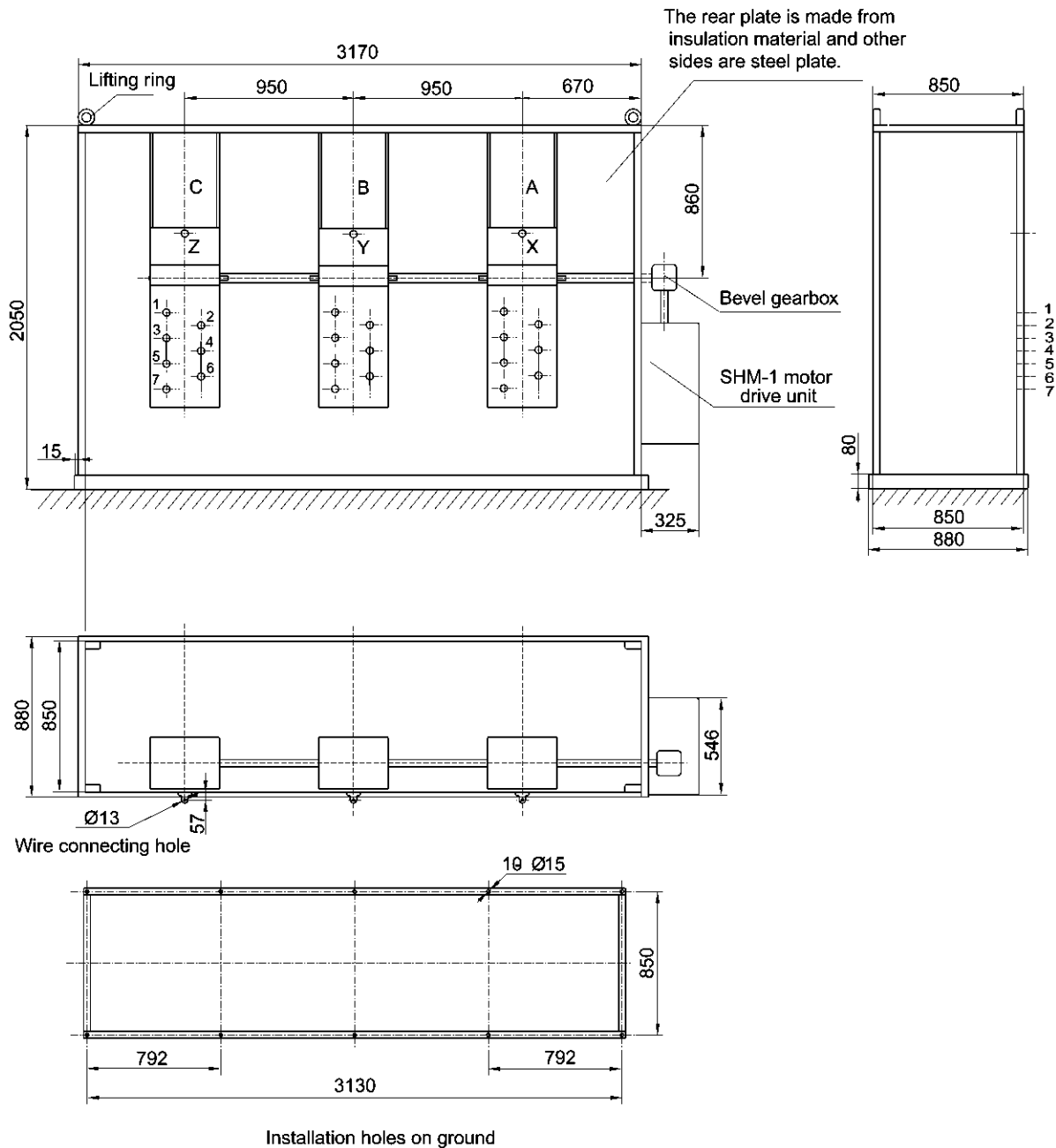

TYPE CZ VACUUM ON-LOAD TAP CHANGER TECHNICAL DATA

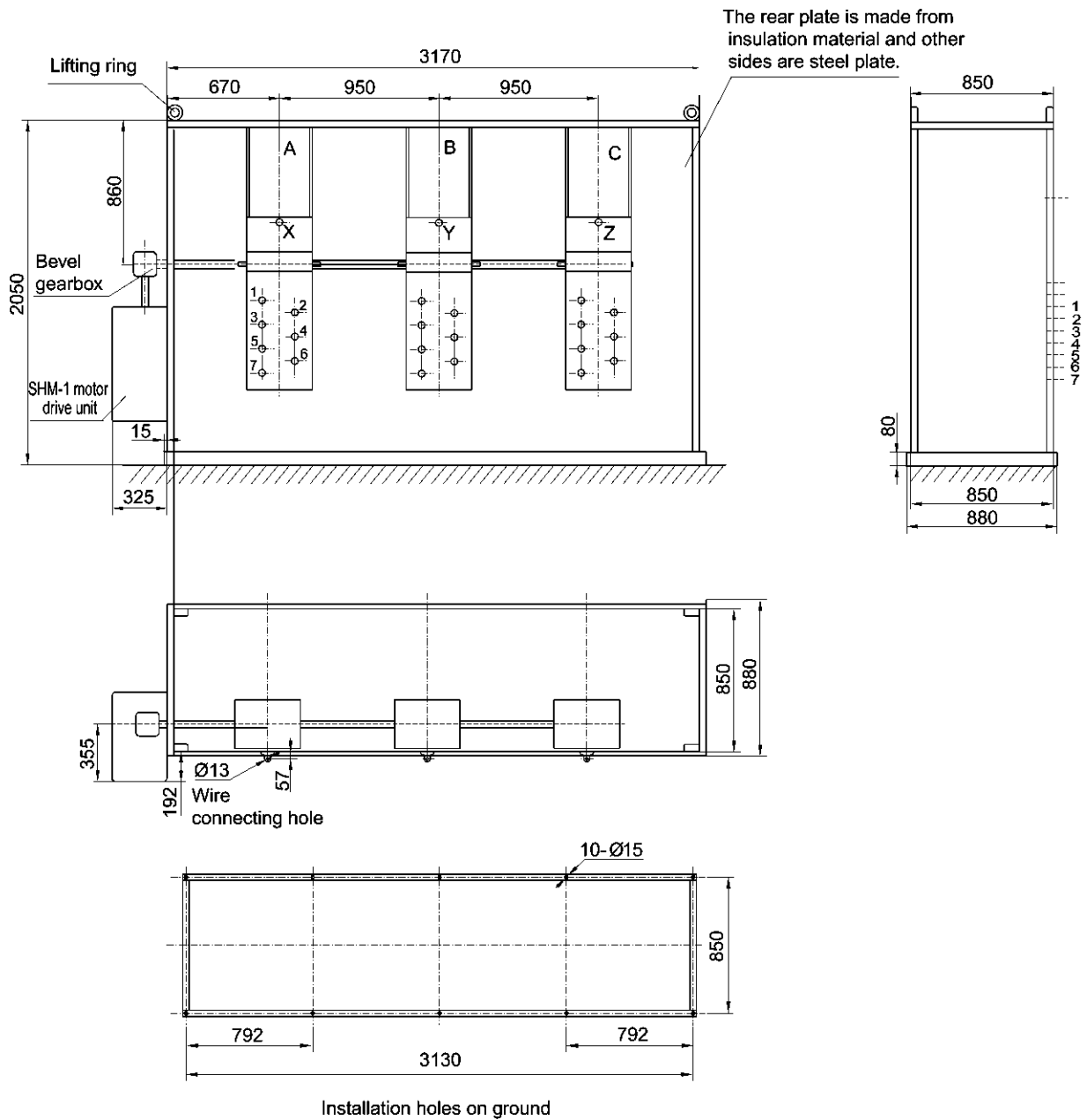
Appendix 7. CZ OLTC mounted in enclosure MDU on the left side, 7 positions

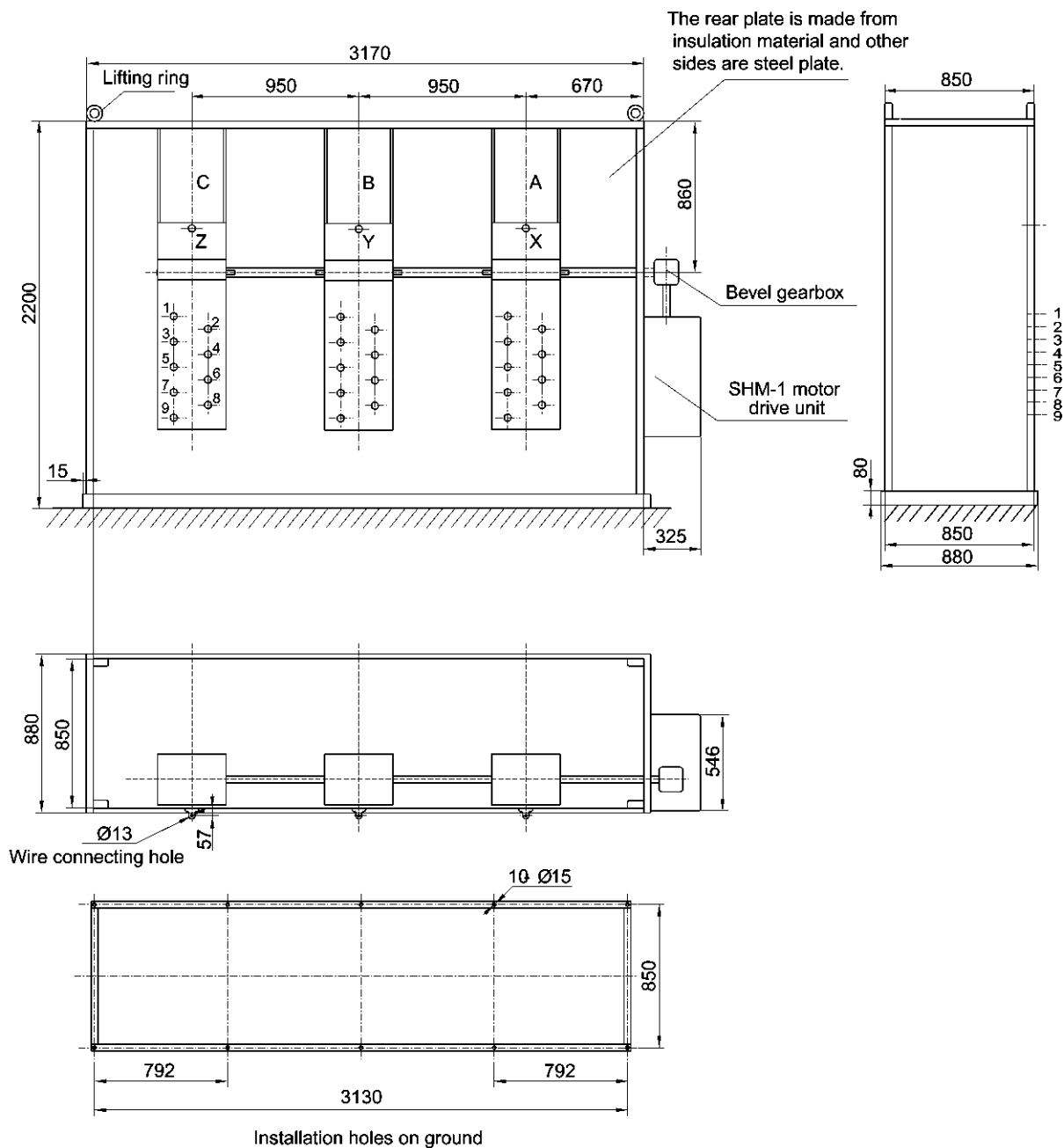
Appendix 8. CZ OLTC mounted in enclosure MDU on the right side, 9 positions

TYPE CZ VACUUM ON-LOAD TAP CHANGER TECHNICAL DATA

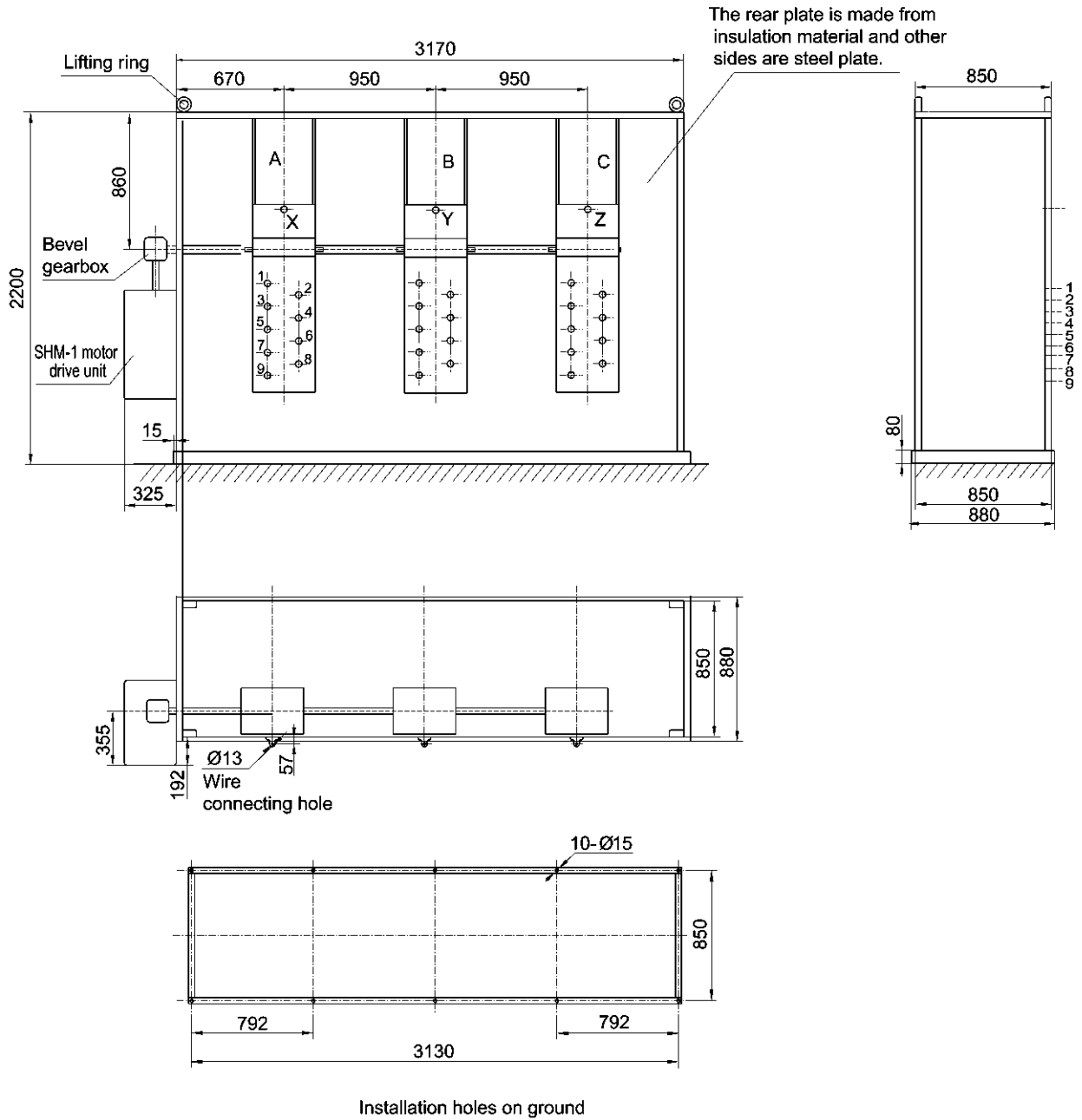
Appendix 9. CZ OLTC mounted in enclosure MDU on the left side, 9 positions

Appendix 10. Disposal drawing of 3 units of single phase CZ OLTC

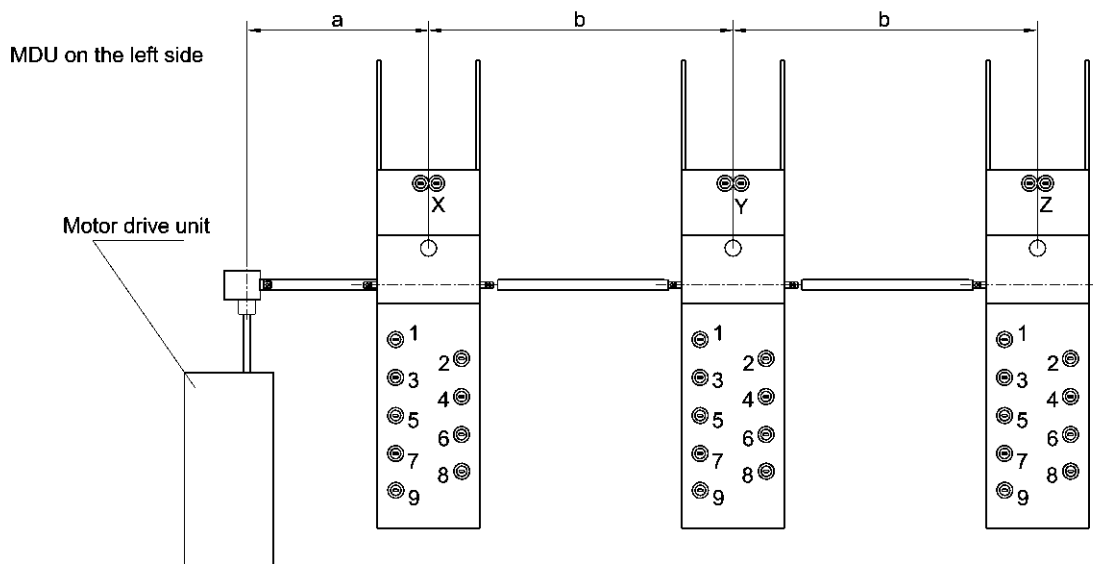
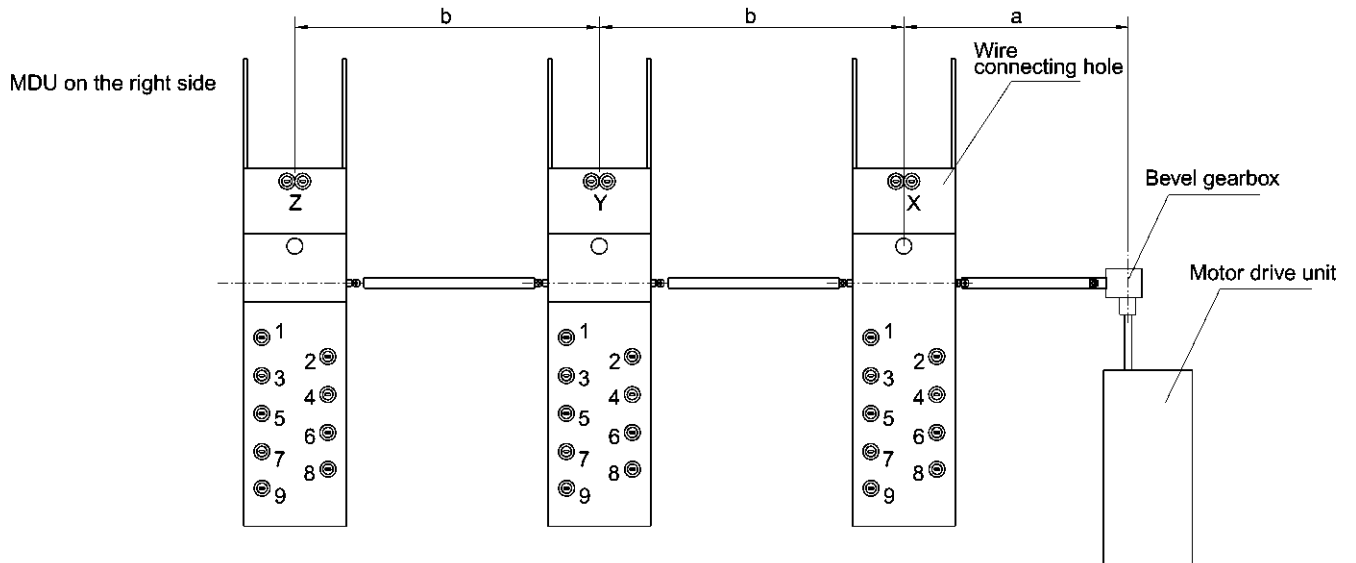

Note:
 Suggested dimensions
 $b \geq 600$, when OLTC is connected at neutral point of star connection;
 $b \geq 950$, when OLTC is used for any other selectable winding connection
 $a \geq 800$

Appendix 11. Installation dimension of SHM-III motor drive unit

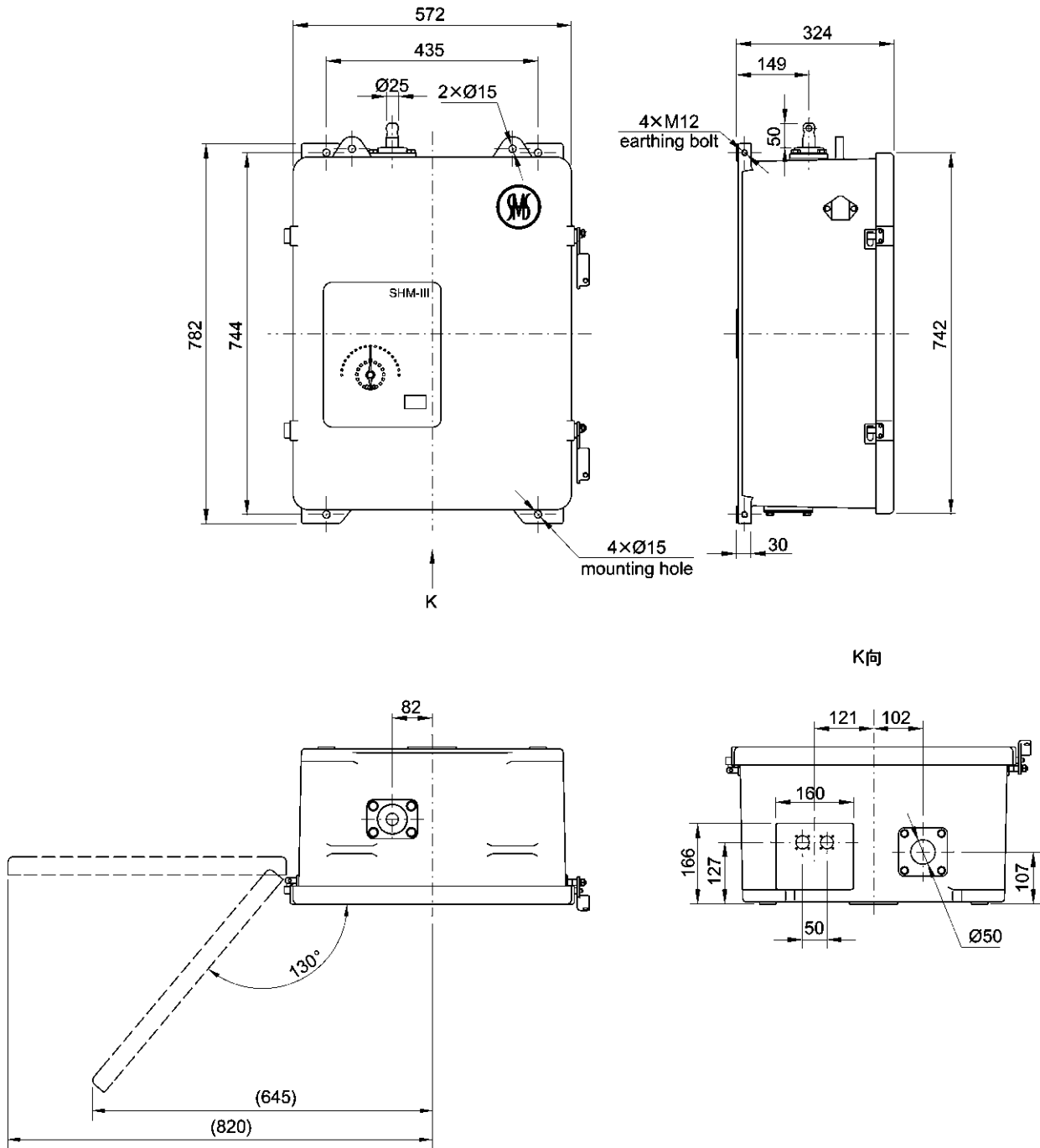

Appendix 12. Installation dimension of CMA7 motor drive unit

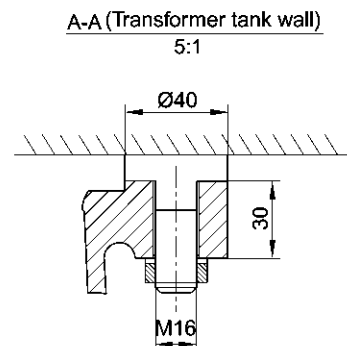
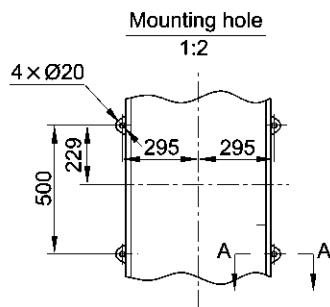
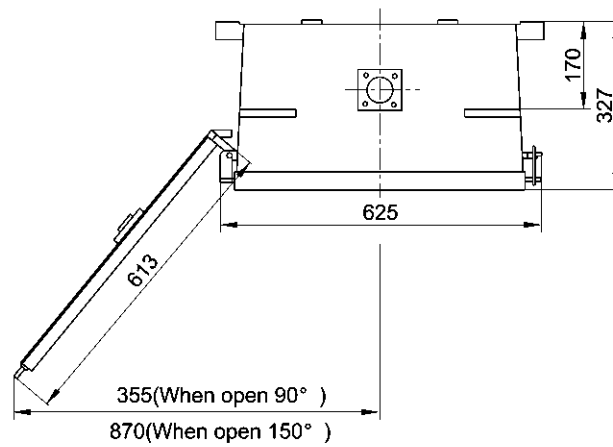
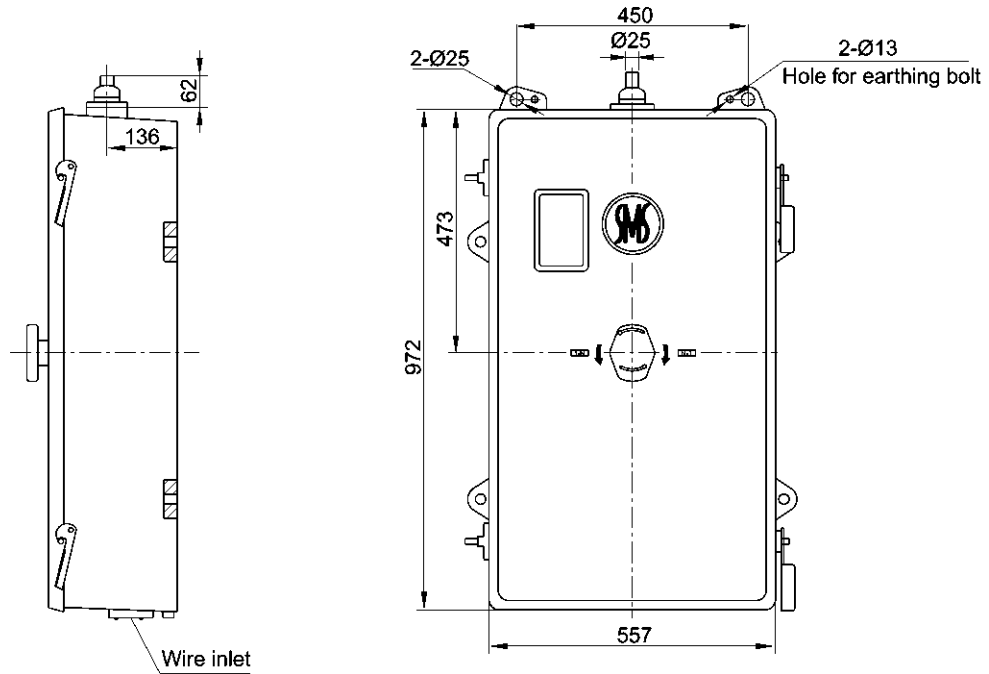

Appendix 13. Installation dimension of bevel gearbox

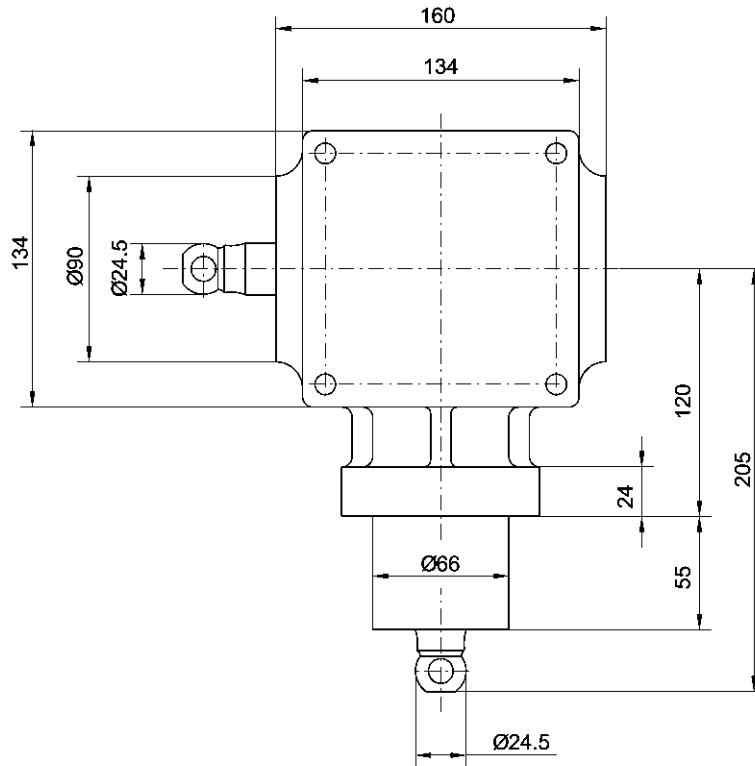

Appendix 14. Schematic drawing of horizontal insulation drive shaft

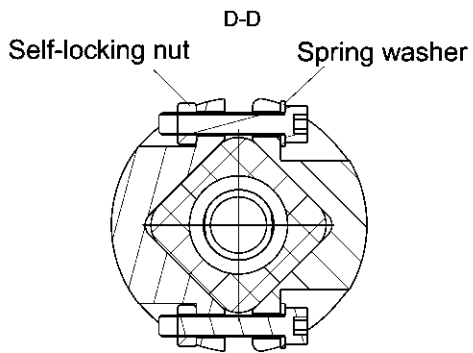
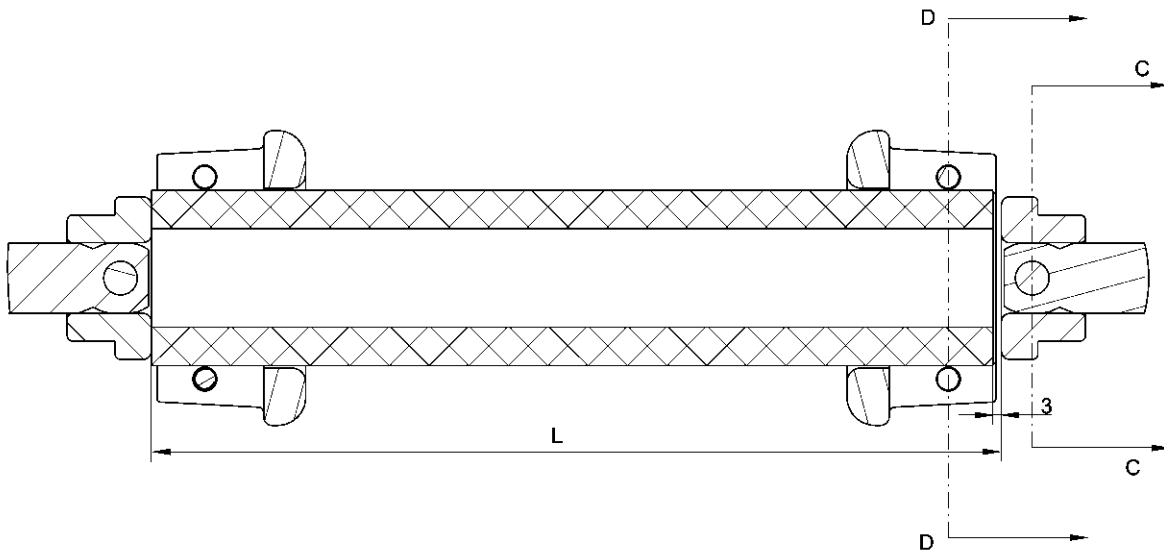

C-C

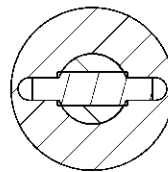

L=Distance between two ends of axis

L-3=Cutting length of the shaft



SHANGHAI HUAMING POWER EQUIPMENT CO., LTD.

Address: 977 Tong Pu Road, Shanghai, P.R.China 200333

Tel: +86 21 5270 3965(direct)

+86 21 5270 8966 Ext.

8688/8123/8698/8158/8110/8658

Fax: +86 21 5270 2715

Web: www.huaming.com

E-mail: export@huaming.com